

TC Figure 20 Deck Construction

REQUIRED LEDGER CONNECTION FOR EXT. DECKS USING MIN 3/8x5" LAG SCREWS W/ WASHERS

JOIST SPAN		6'	8'	10'	12'
SPACING OF LAG SCREWS	12"	2 SCREWS	2 SCREWS	2 SCREWS	3 SCREWS
	16"	2 SCREWS	3 SCREWS	3 SCREWS	4 SCREWS
	24"	4 SCREWS	4 SCREWS	4 SCREWS	6 SCREWS

LAGS INTO MANUFACTURED LUMBER MUST HAVE APPROVAL DOCUMENTATION OR HAVE SOLID WOOD RIM BACKING W/ PENETRATING LAG SCREWS

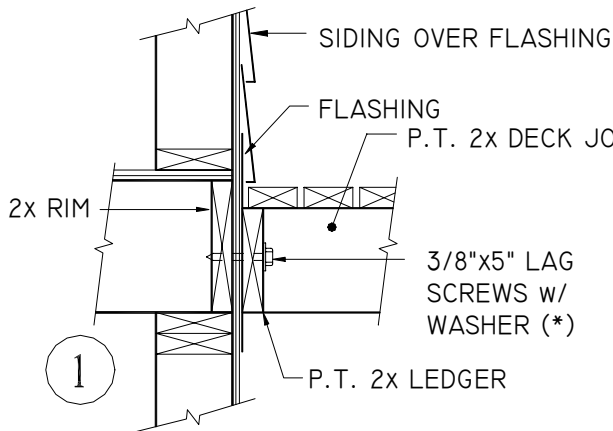
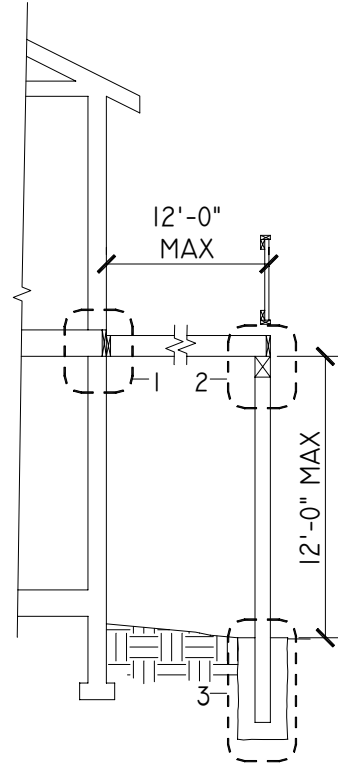

(*) FASTENERS USED IN P.T. WOOD MUST BE AS SPECIFIED BY WOOD MFR

